

Reflector: matt aluminium louvre.
Diffuser: in vandal resistant polycarbonate and self-extinguishing V2, UV stabilized.

1214 Clima								
		CNR-F		CELL-F		CNRL-F		Lamps (Ta=25°C)
wattage	colour	weight	code	weight	code	weight	code	Kelvin - ølm - Ra
SAP-E 70*	graphite	4.60	422351-00					
SAP-E 100	graphite	4.90	422352-00					
FLC 42T/E	graphite			4.00	422353-00			4000K - 3200lm - Ra 1b
JM-E 100	graphite					5.00	422354-00	3200K - 9000lm - Ra 2a

* use lamp with built-in igniter

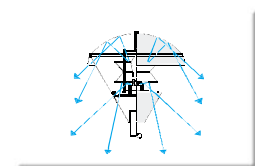
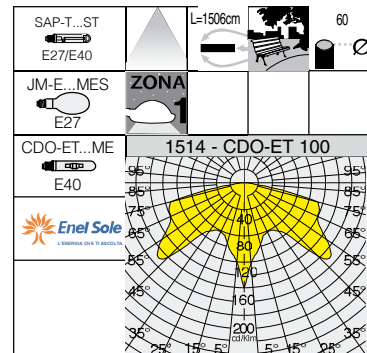
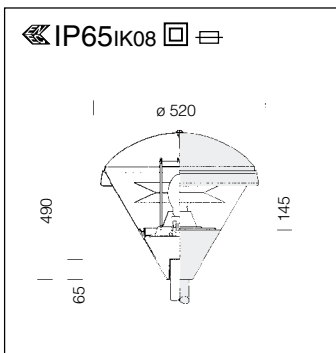

Reflector: black aluminium louvre.
1514 Zona 1 with black aluminium louvre.
Diffuser: in vandal resistant polycarbonate and self-extinguishing V2, UV stabilized.

1514 Clima - zona 1							
		CNRL-F				Lamps (Ta=25°C)	
wattage	colour	weight	code				Kelvin - ølm - Ra
SAP-T 70	graphite	4.80	422361-00				2000K - 6000lm - Ra 4
SAP-T 70	s. silver	4.80	422331-00				
SAP-T 100	graphite	5.10	422362-00				2000K - 9000lm - Ra 4
SAP-T 100	s. silver	5.10	422333-00				
JM-E 70	graphite	5.00	422363-00				4000K - 5000lm - Ra 2a
JM-E 70	s. silver	5.00	422335-00				
JM-E 100	graphite	5.10	422364-00				3200K - 9000lm - Ra 2a
JM-E 100	s. silver	5.10	422337-00				
CDO-ET 100	graphite	5.10	422365-00				2800K - 8300lm - Ra 1b
CDO-ET 100	s. silver	5.10	422338-00				